



SAMPLE APPROVAL SHEET

C N _____

P N CG₁₁-3838IRPC/D20A90

S D _____

Add - - 00 - - B

-

P D

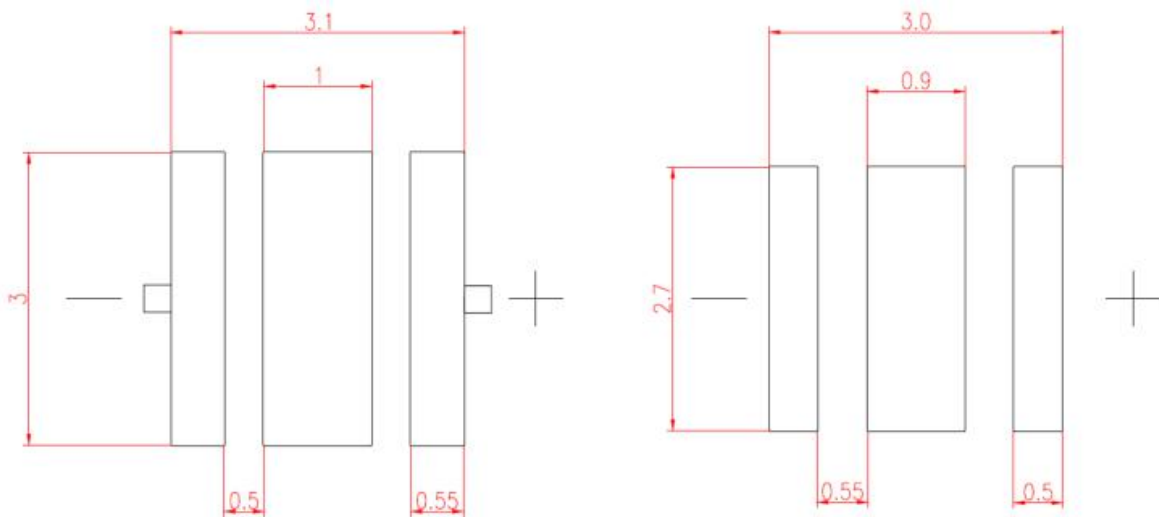
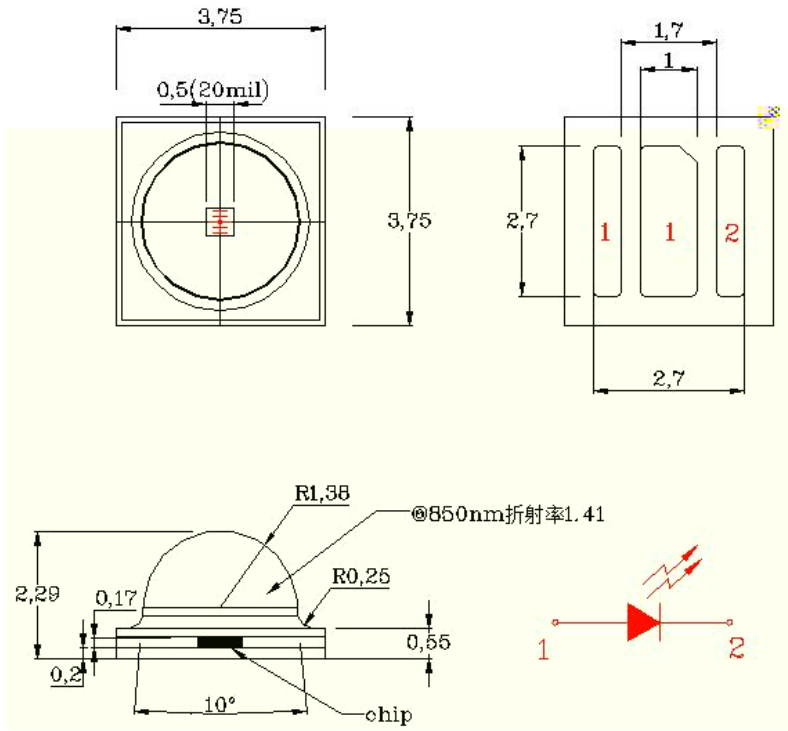

0.

+ 0 - 00 + 0 -

Typical Electro-Optical Characteristics Curve

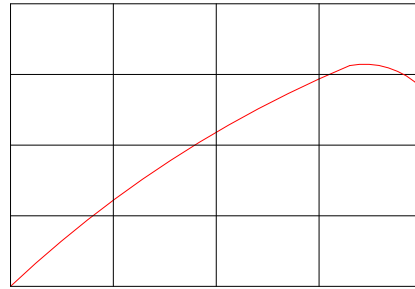
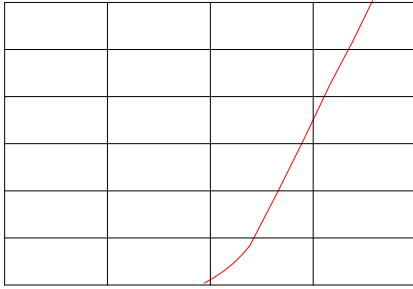

v

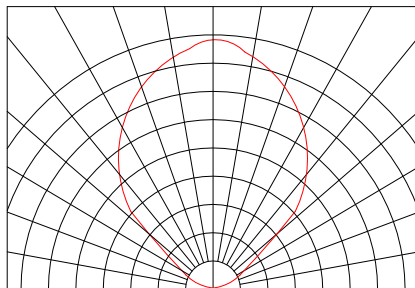
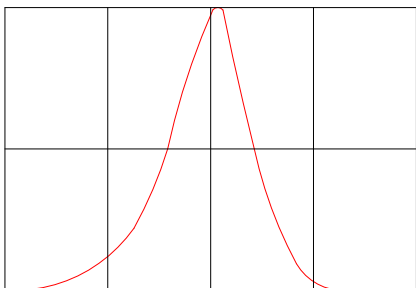
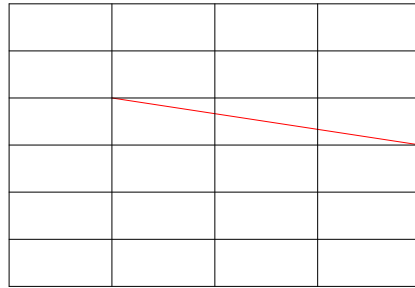

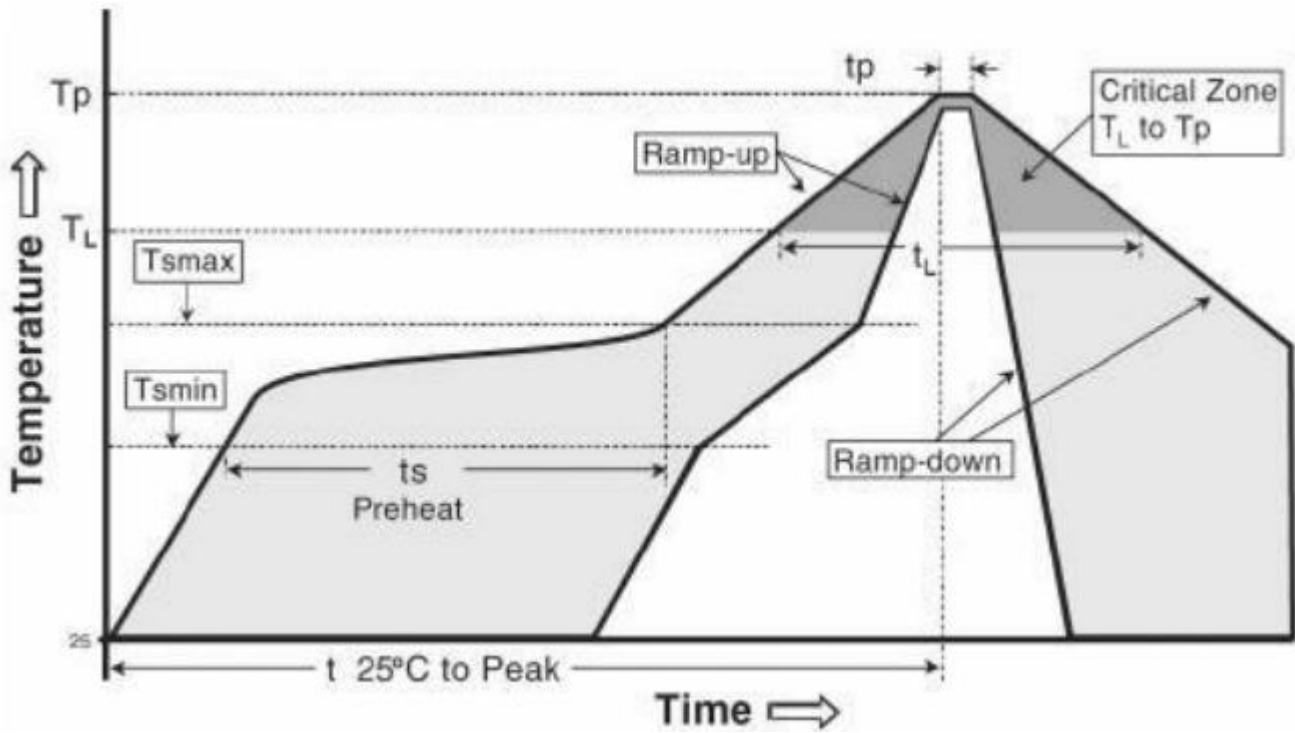

()	()	0
()	()	00
() ()	()	0- 0
- ()	()	/
()	()	0- 0
()	()	0
()	()	0
- ()	()	/

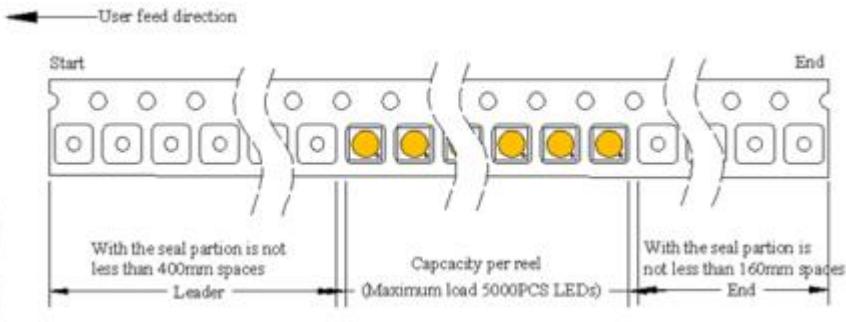
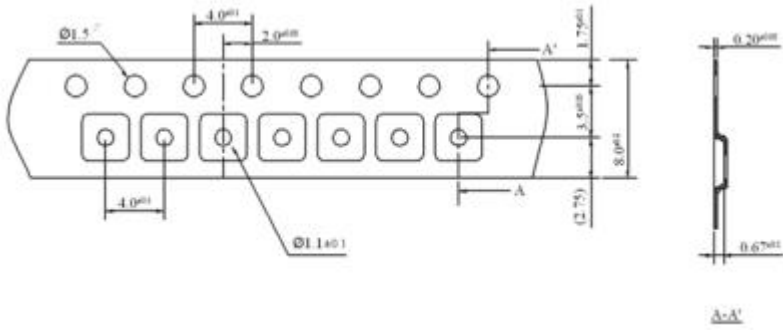

- 000 /
- / 0 0.
- 0. -0.
- 0
- / ,

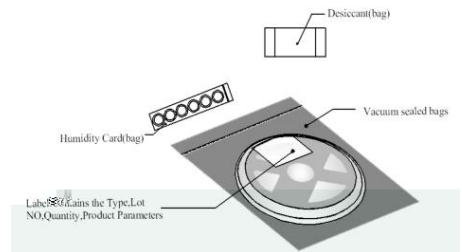
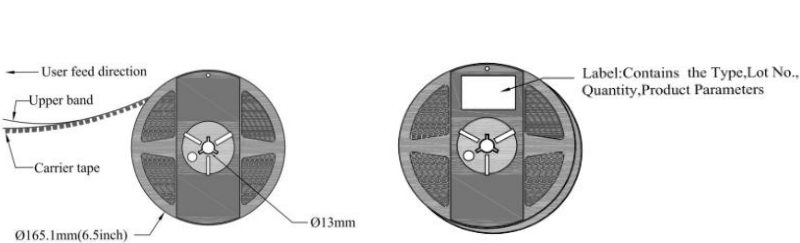



+ 0 - 00 + 0 -
 -